

CROSSHEAD ECF-20/SE

COEXTRUSION SELF-CENTERING

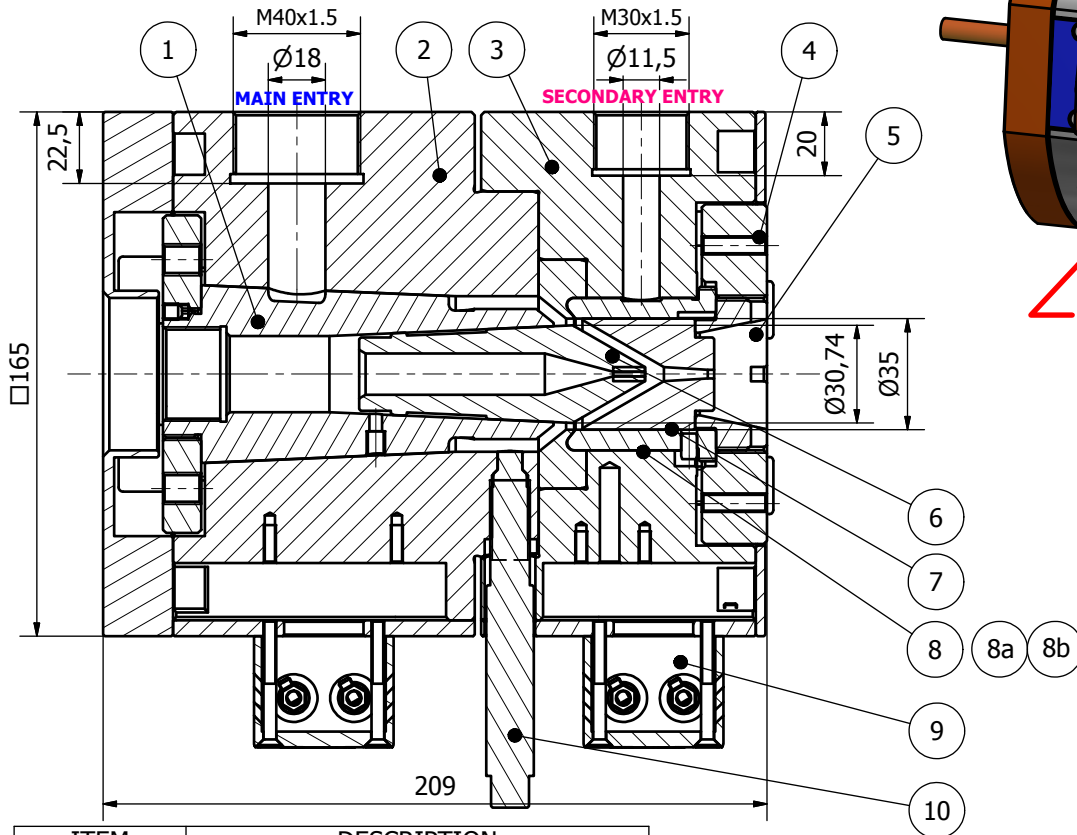

ITEM	DESCRIPTION
1	CARTRIDGE
2	HEAD BODY WITH H. CARTRIDGES
3	HOLDING RING PLATE
4	HOLDING NUT FOR RING
5	ADJUSTING DIE NUT
6	TIP
7	DIE
8	NEUTRAL RING
8a	RING FOR STRIPE
8b	RING FOR SKIN
9	POWER CONNECTION
10	DYNISCO CAP

ELECTRICAL POWER HEAD BODY ZONE: 1600W
ELECTRICAL POWER DIE AREA: 1600W

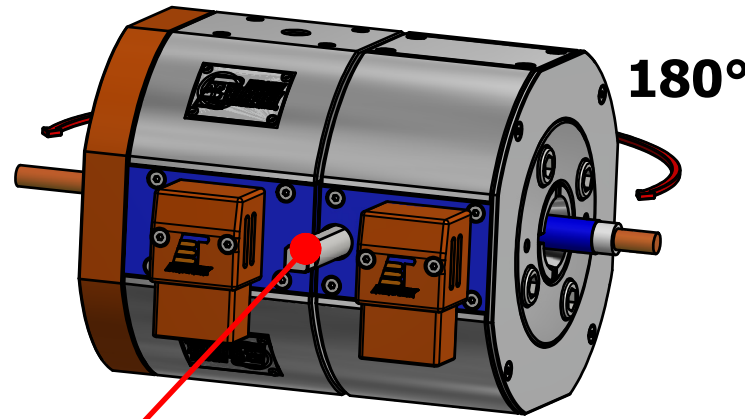

PRESSURE CONTROL / TEMPERATURE

APPLICATIONS	
	SINGLE LAYER
	STRIPE
	SKIN
	FLAT CABLE

Ø MAX CONDUCTOR: 12mm
 Ø MAX DIE: 20mm

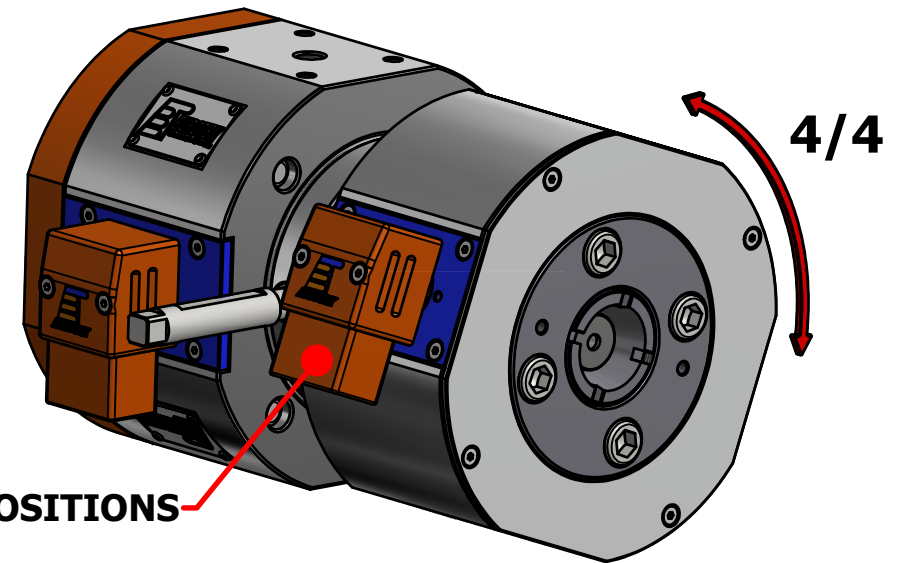

MOUNTS IN 3 POSITIONS



CROSSHEAD ECF-20/SE

EUROTEK S.r.l.
 66034 LANCIANO (Ch)- Italy
 Phone:(+39) 0872 72581 FAX:(+39) 0872 711978
 www.eurotek-italy.it
 E-mail: info@eurotek-italy.it

