

CROSSHEAD ECF-40/SE

COEXTRUSION SELF-CENTERING

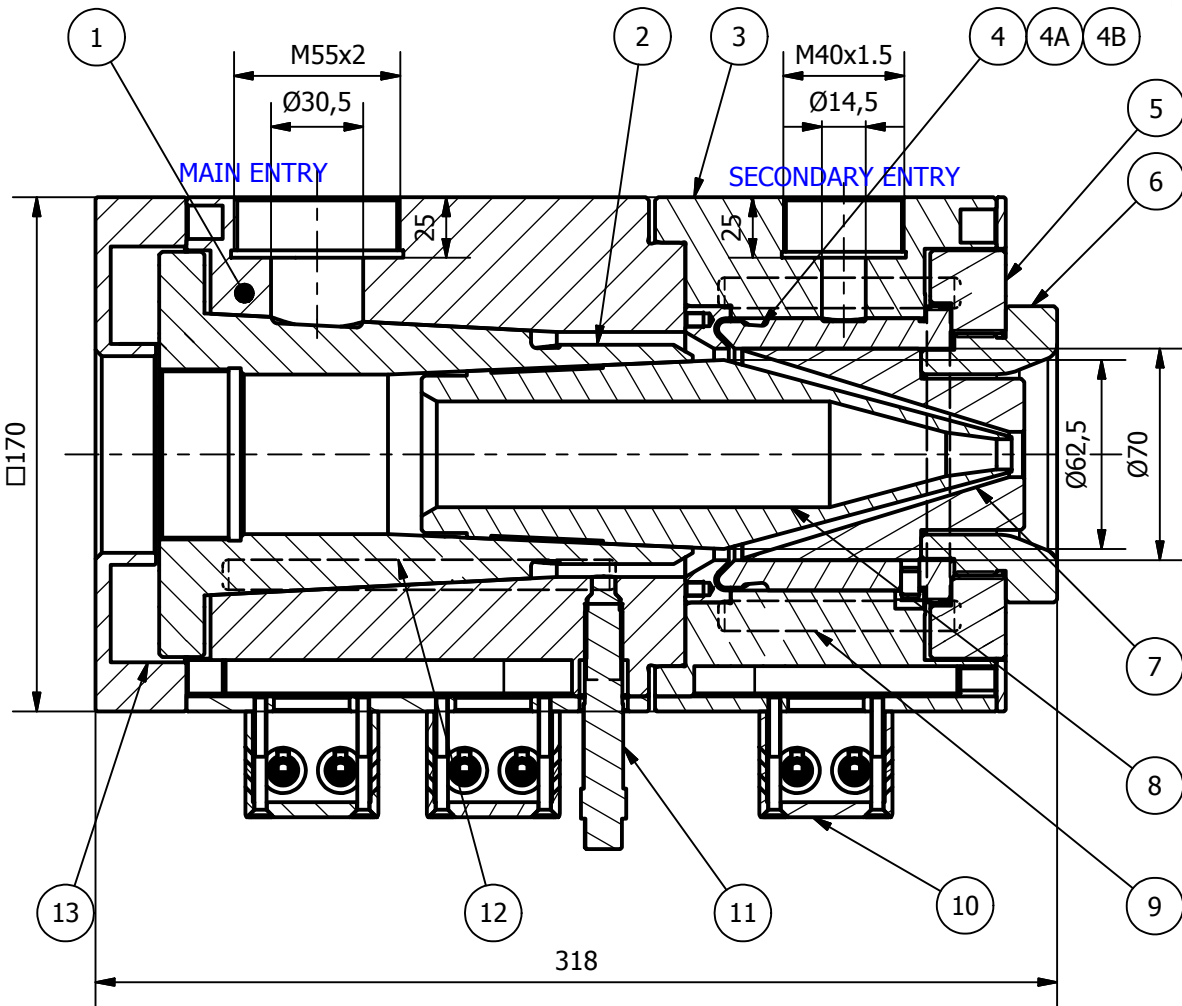

ELECTRICAL POWER HEAD BODY ZONE: 4000W
ELECTRICAL POWER DIE AREA: 1000W

ITEM	DESCRIPTION
1	HEAD BODY WITH H. CARTRIDGES
2	CARTRIDGE
3	HOLDING RING PLATE
4	RING FOR SKIN
4A	NEUTRAL RING
4B	RING FOR STRIPING
5	HOLDING NUT FOR RING
6	ADJUSTING DIE NUT
7	DIE
8	TIP
9	H. CARTRIDGES 220V 250W
10	POWER CONNECTOR
11	DYNISCO
12	H. CARTRIDGES 220V 500W
13	REAR COVER

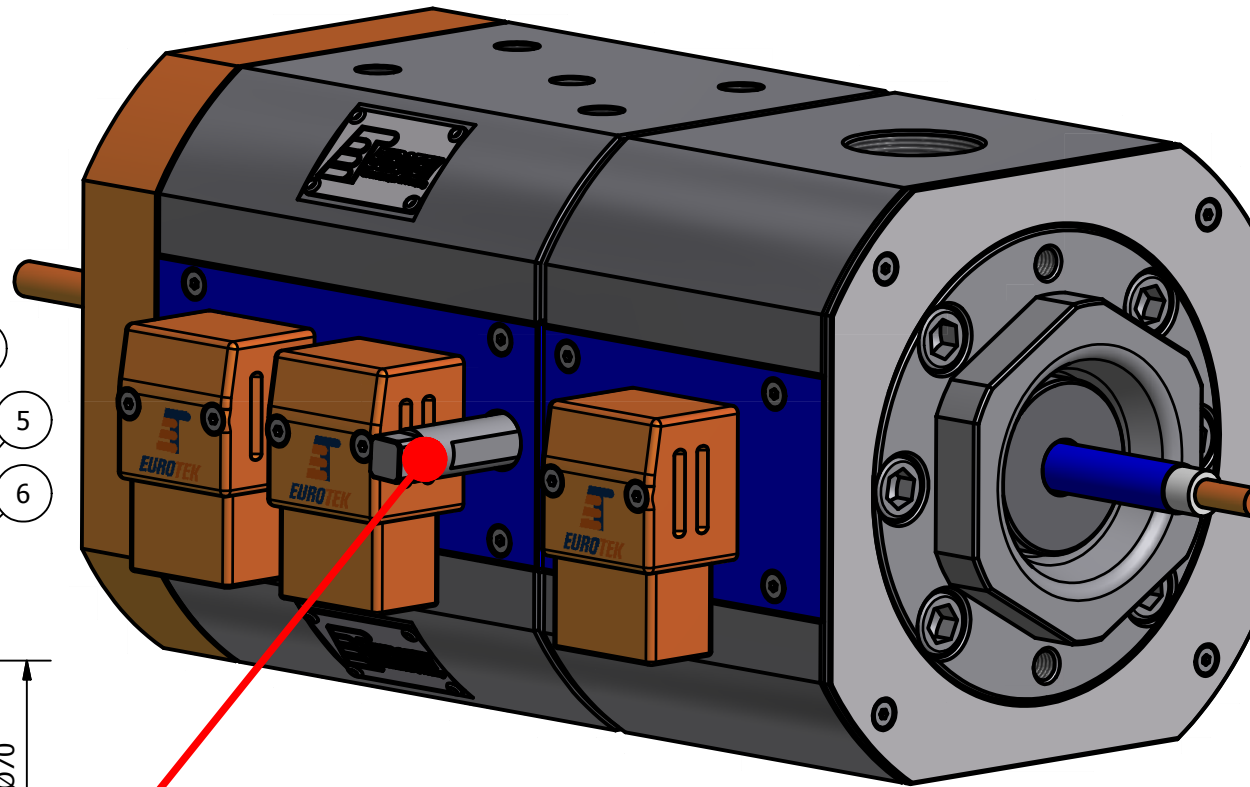

PRESSURE CONTROL / TEMPERATURE

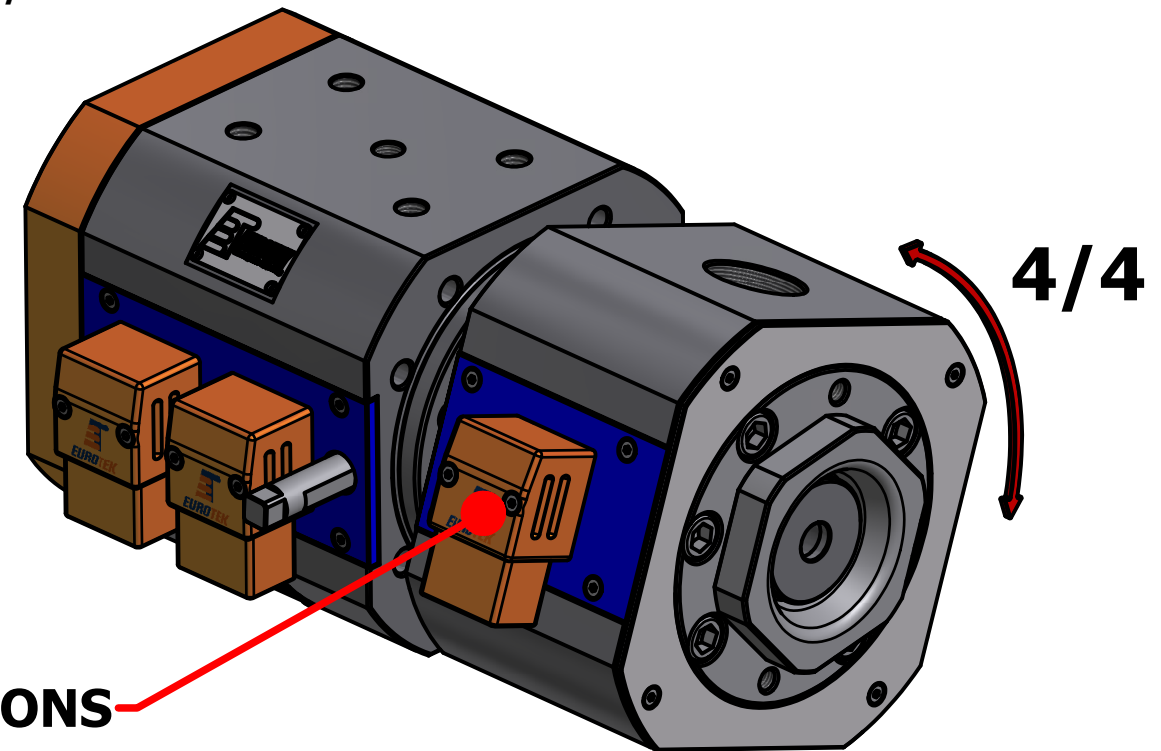

MOUNTS IN 3 POSITIONS

APPLICATIONS	
	SINGLE LAYER
	STRIPE
	SKIN
	FLAT CABLE

MAX CONDUCTOR: 30 mm
MAX OVER INSULATION: 35mm
MAX TUBE DIE DIAMETER: 40mm



CROSSHEAD ECF-40/SE

EUROTEK S.r.l.
 66034 LANCIANO (Ch)- Italy
 Phone:(+39) 0872 72581 FAX:(+39) 0872 711978
www.eurotek-italy.it
 E-mail: info@eurotek-italy.it

