

CROSSHEAD ECM25/DS

MANUAL-CENTERING DOUBLE LAYER

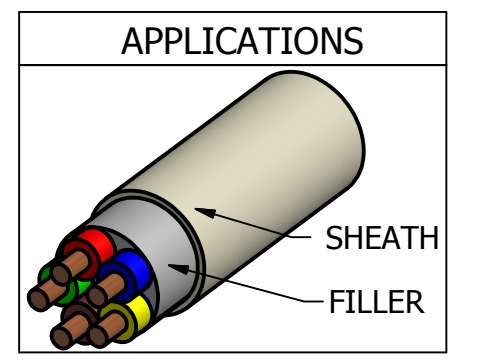

MAX CONDUCTOR: 25mm
 MAX OVER INSULATION: 35mm
 MAX PASSAGE DIE: 40 mm

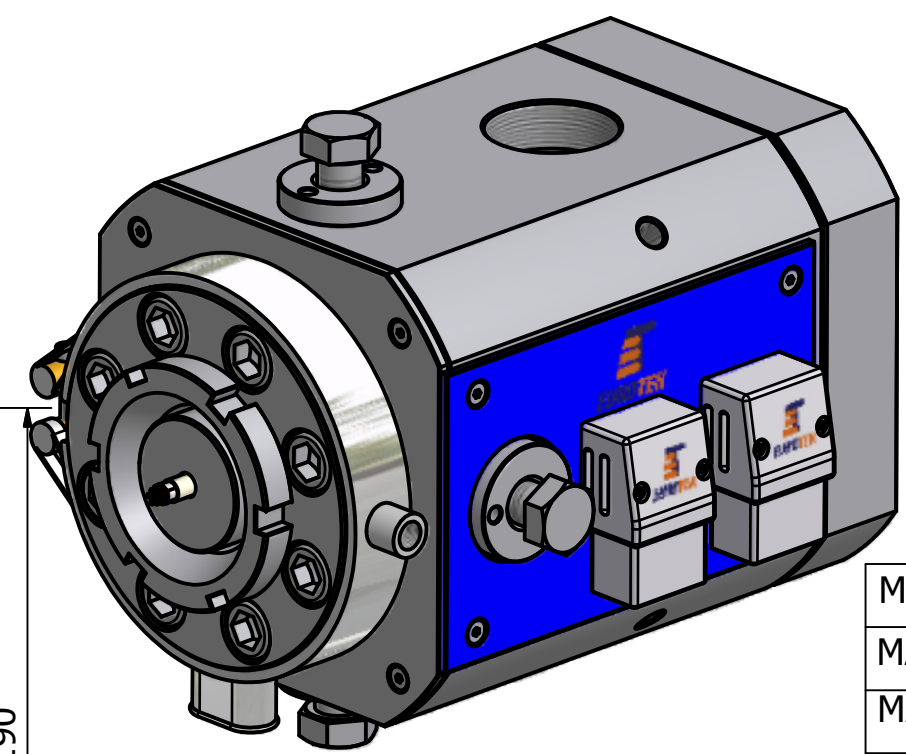
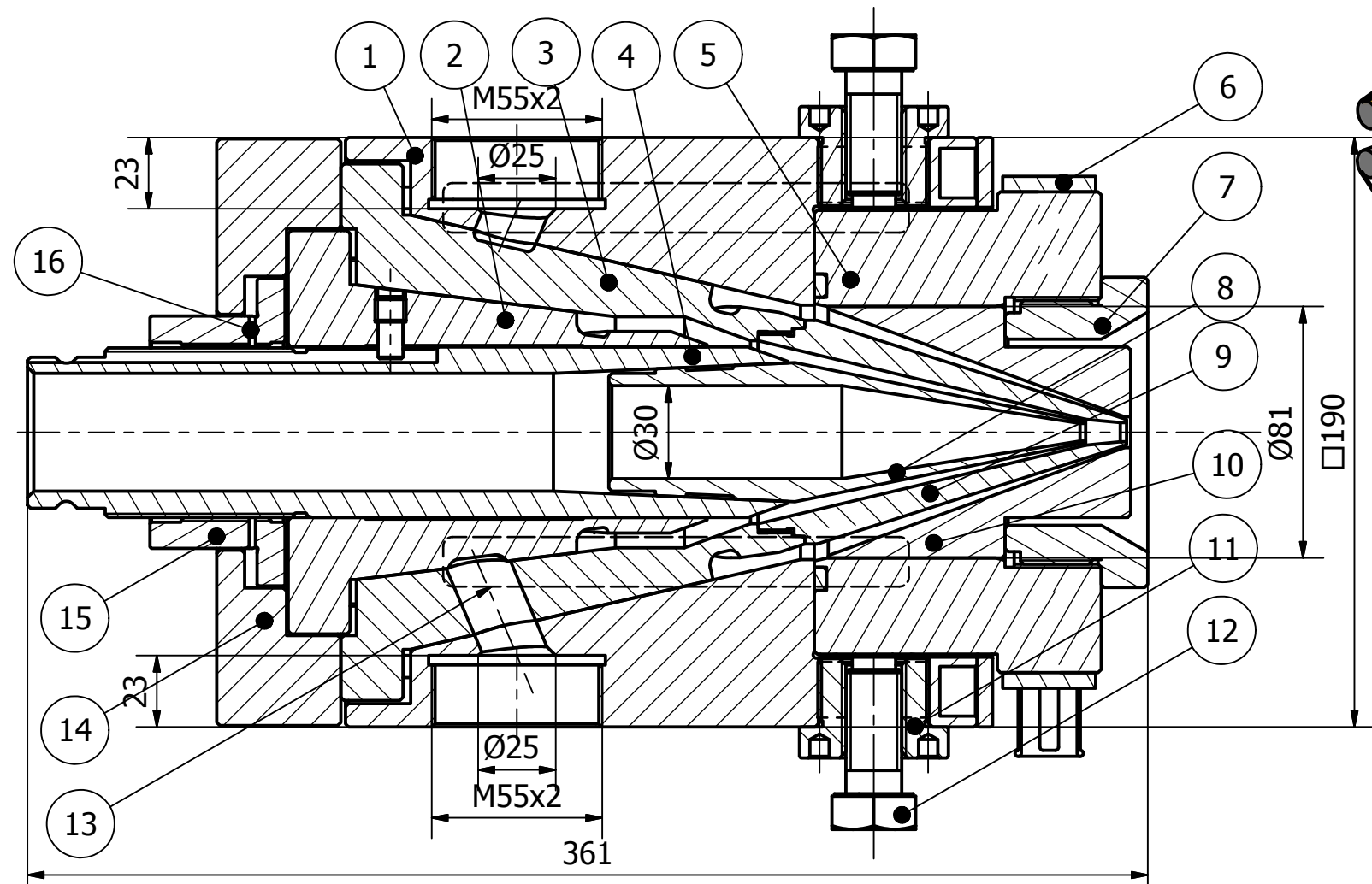
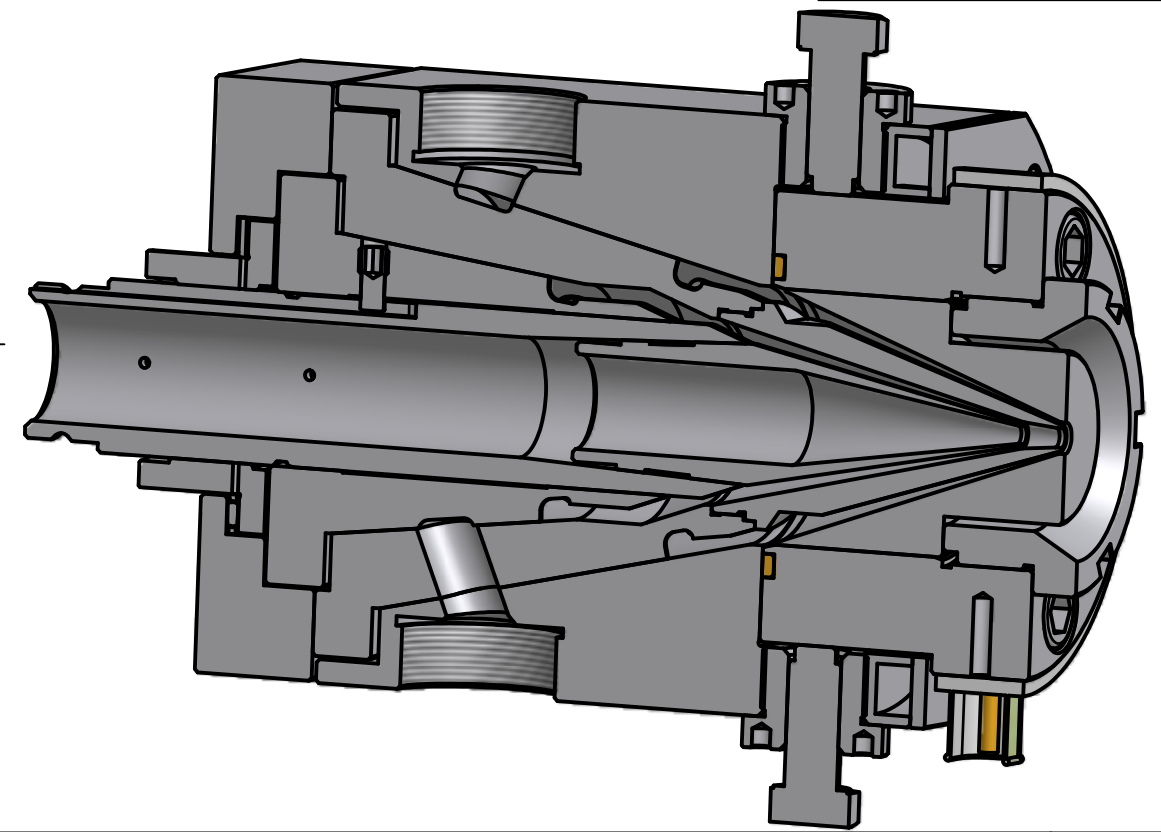

ITEM	DESCRIPTION
1	HEAD BODY
2	INNER CARTRIDGE
3	OUTER CARTRIDGE
4	HOLDING WIRE GUIDE
5	MANUAL HOLDING DIE
6	HEATER 300W
7	HOLDING DIE NUT
8	TIP
9	INTERMEDIATE DIE
10	BOTTOM DIE
11	BUSHES
12	CENTERING SCREWS
13	H. CARTRIDGE 3200W
14	THRUST BEARING PLATE
15	ADJUSTING NUT HOLDING WIRE GUIDE
16	BALL BEARING



CROSSHEAD ECM25/DS

EUROTEK S.r.l.
 66034 LANCIANO (Ch)- Italy
 Phone:(+39) 0872 72581 FAX:(+39) 0872 711978
www.eurotek-italy.it
 E-mail: info@eurotek-italy.it

