

# CROSSHEAD ECM25-M

MANUAL-CENTERING FOR SINGLE LAYER

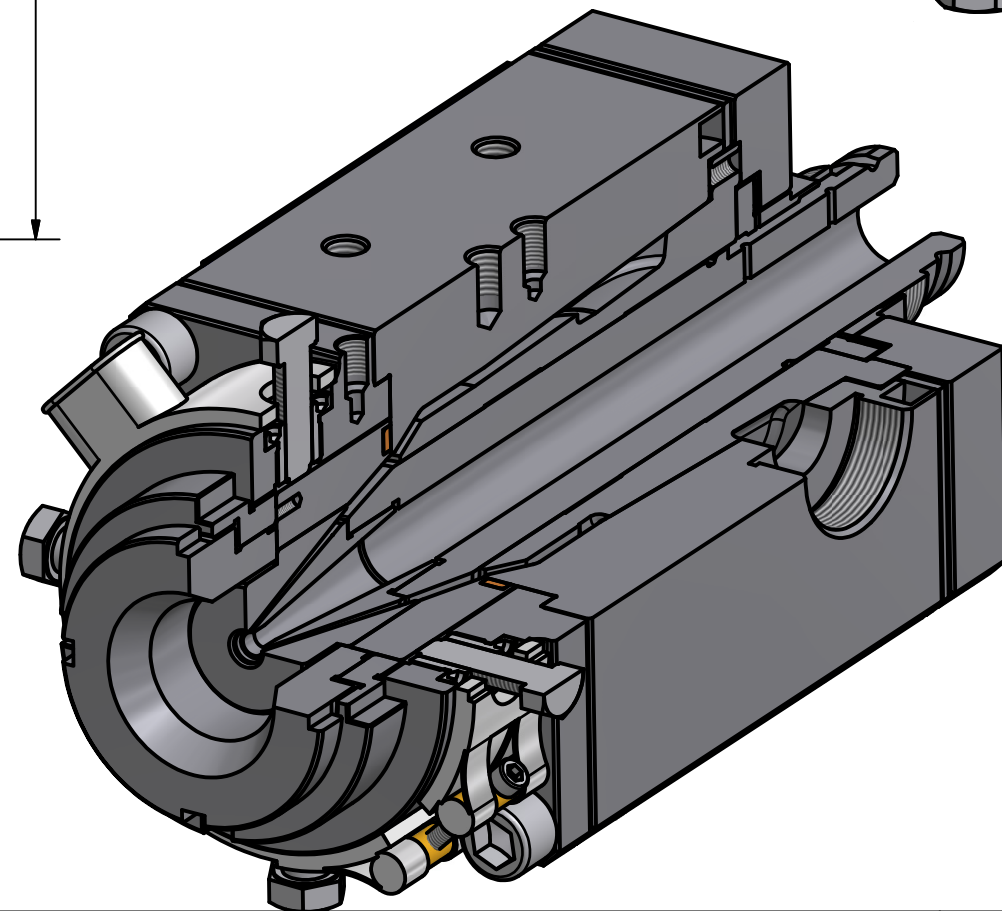

### APPLICATIONS

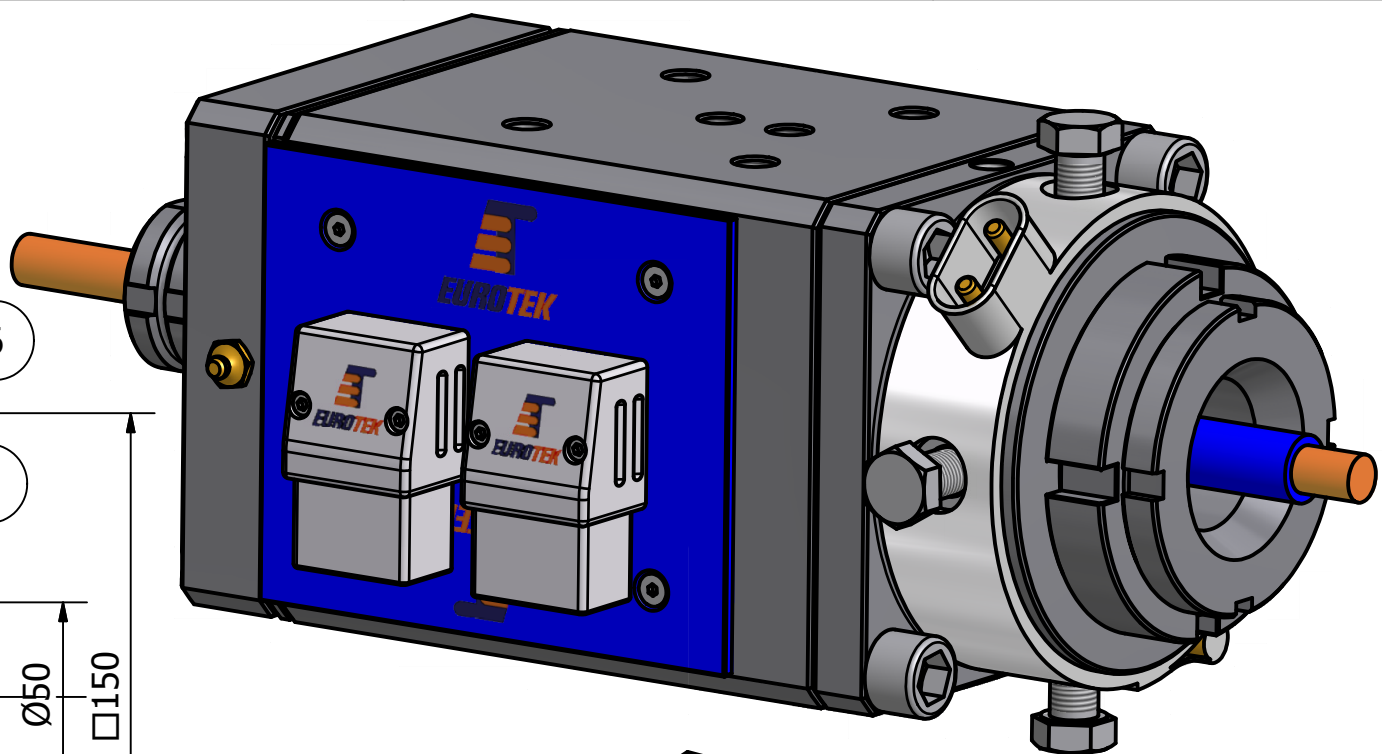
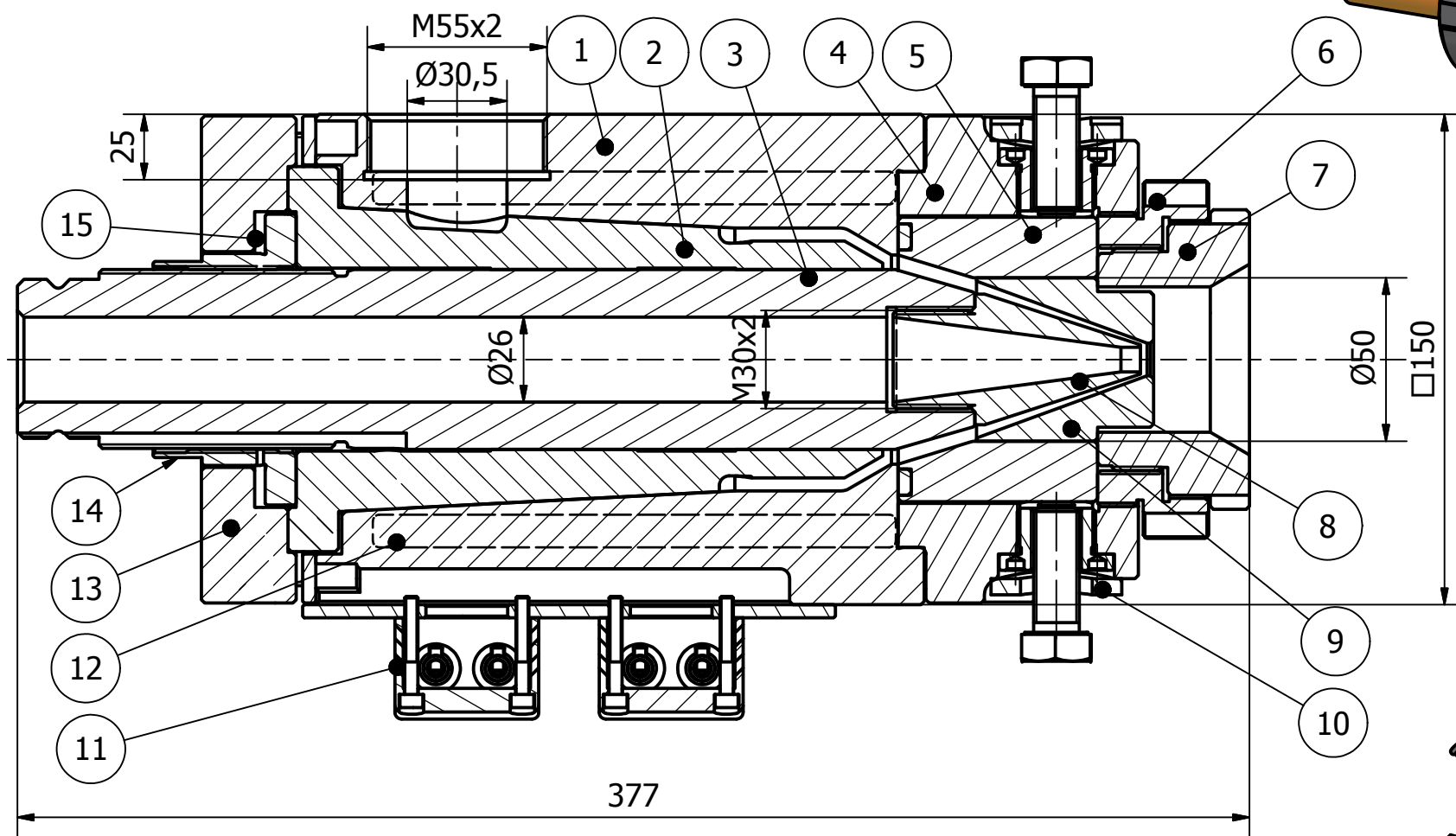
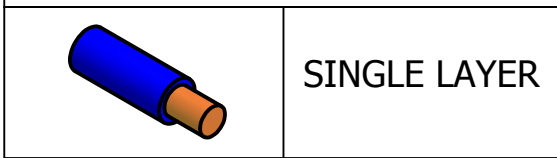

SINGLE LAYER

MAX CONDUCTOR : 25mm  
 MAX OVER INSULATION: 30mm  
 MAX PASSAGE DIE: 40mm

ITEM	DESCRIPTION
1	HEAD BODY
2	CARTRIDGE
3	HOLDING WIRE GUIDE
4	FRONT PLATE
5	HOLDING DIE FOR MANUAL CENTERING
6	HOLDING NUT FOR HOLDING DIE
7	ADJUSTING DIE NUT
8	TIP
9	DIE
10	HEATER (600W)
11	TAP
12	H. CARTRIDGE (2400W)
13	THRUST BEARING PLATE
14	ADJUSTING NUT FOR HOLDING WIRE GUIDE
15	BALL BEARING

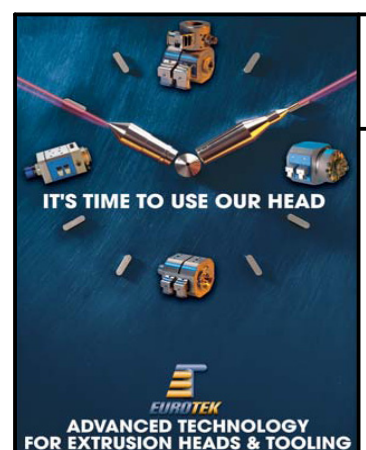

## CROSSHEAD ECM25-M

EUROTEK S.r.l. C.da Villa Andreoli,215/A  
 66034 LANCIANO (Ch)- Italy  
 Phone:(+39) 0872 72581 FAX:(+39) 0872 711978  
 www.eurotek-italy.it  
 E-mail: info@eurotek-italy.it

