

CROSSHEAD ECM35-M

MANUAL-CENTERING FOR SINGLE LAYER

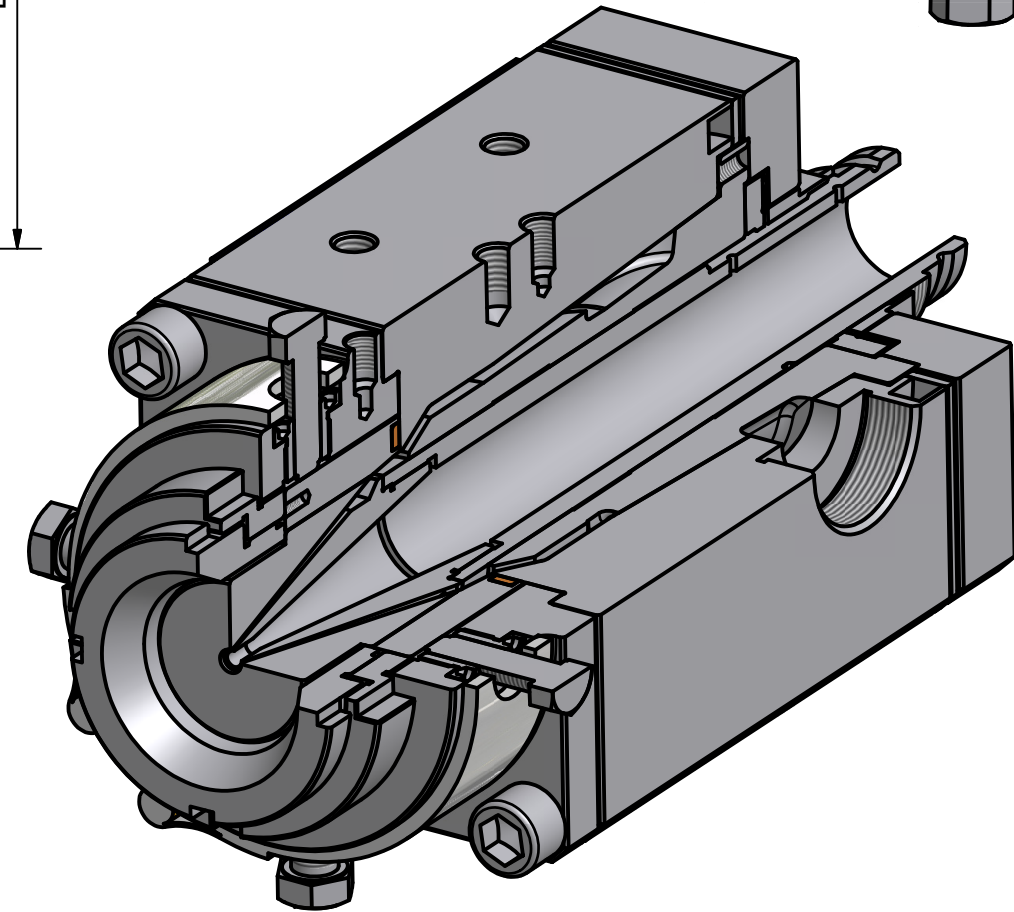
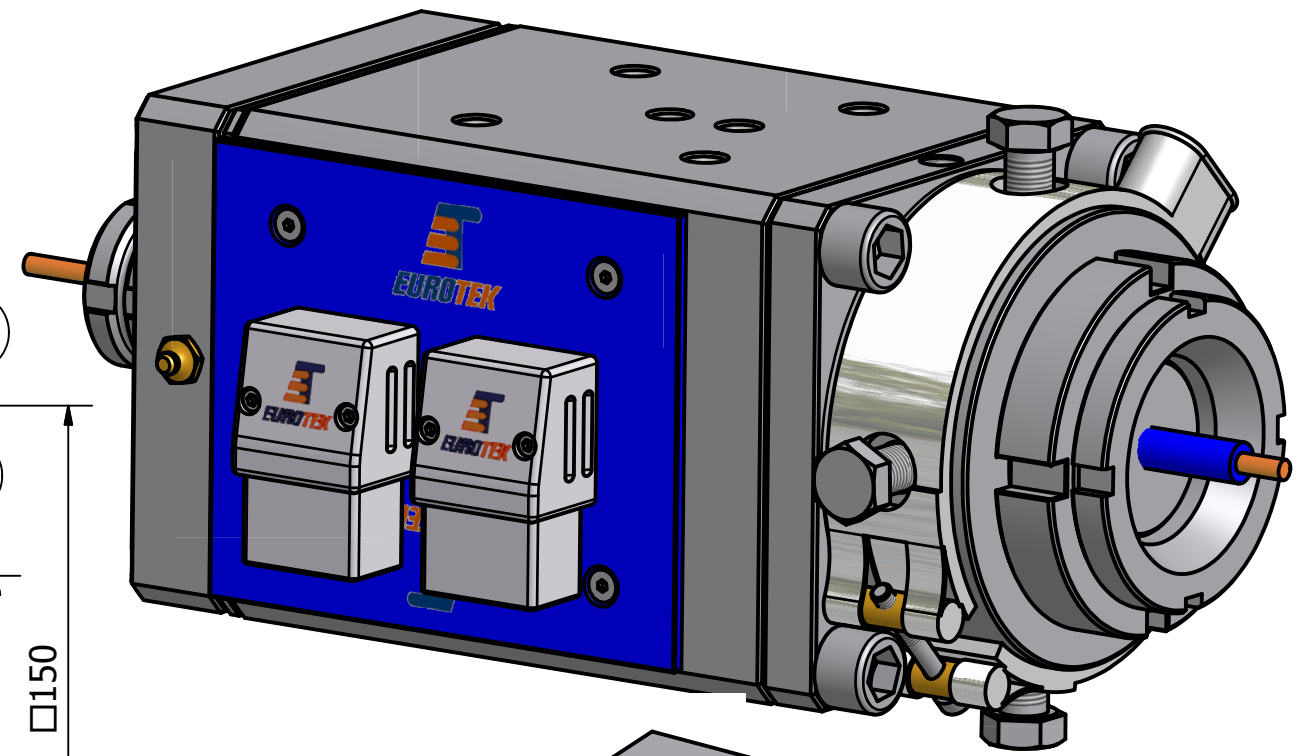
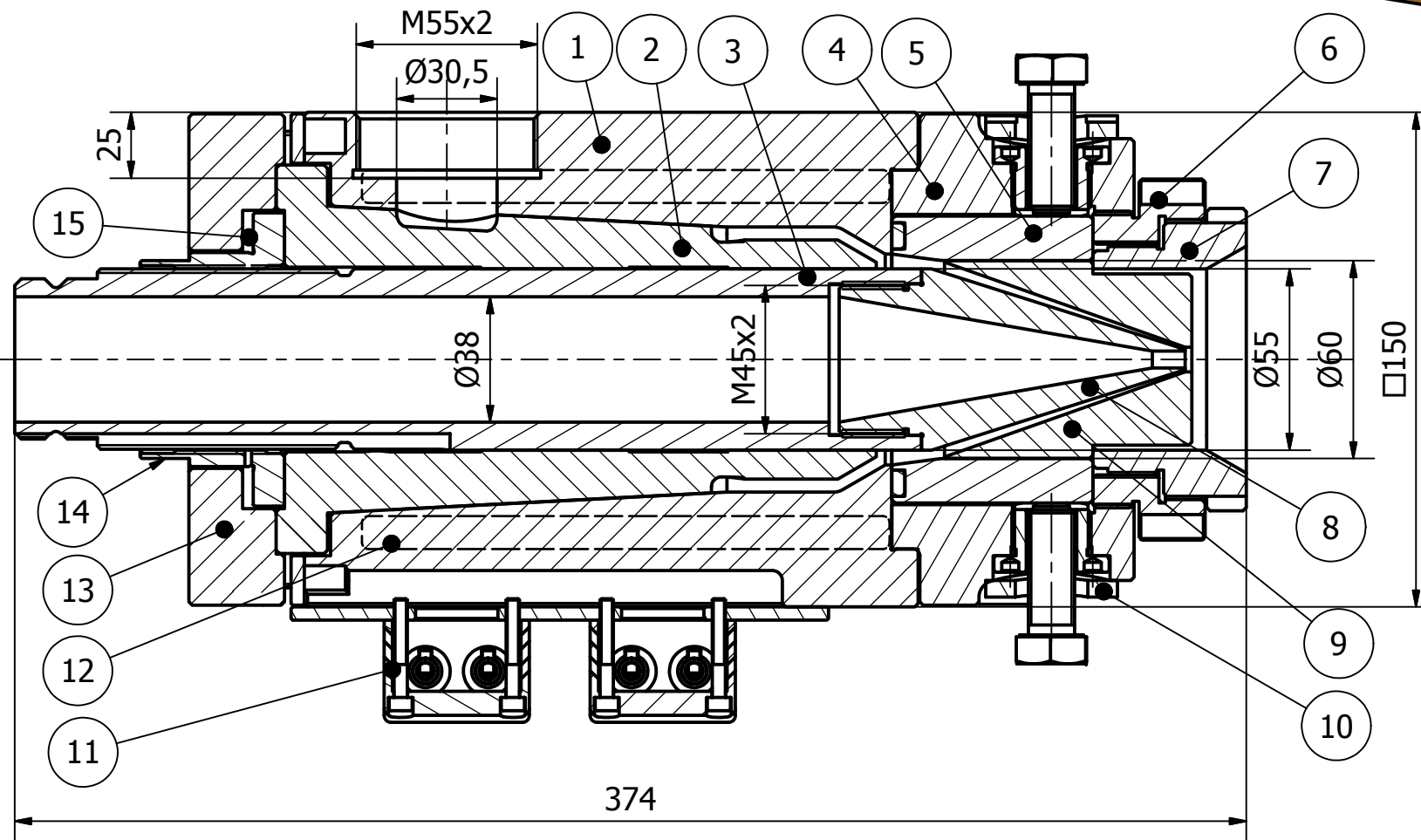

ITEM	DESCRIPTION
1	HEAD BODY
2	CARTRIDGE
3	HOLDING WIRE GUIDE
4	FRONT PLATE
5	HOLDING DIE FOR MANUAL CENTERING
6	HOLDING NUT FOR HOLDING DIE
7	ADJUSTING DIE NUT
8	TIP
9	DIE
10	HEATER (600W)
11	TAP
12	H. CARTRIDGE (2400W)
13	THRUST BEARING PLATE
14	ADJUSTING NUT FOR HOLDING WIRE GUIDE
15	BALL BEARING

APPLICATIONS

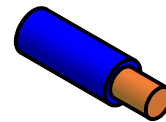

SINGLE LAYER

MAX CONDUCTOR : 35mm
 MAX OVER INSULATION: 40mm
 MAX PASSAGE DIE: 50mm

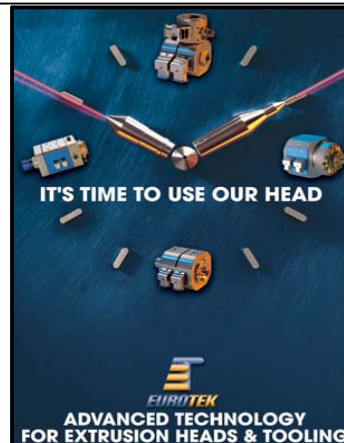

CROSSHEAD ECM35-M

EUROTEK S.r.l. C.da Villa Andreoli,215/A
 66034 LANCIANO (Ch)- Italy
 Phone:(+39) 0872 72581 FAX:(+39) 0872 711978
www.eurotek-italy.it
 E-mail: info@eurotek-italy.it

