

CROSSHEAD ECS-20/C

SPHERICAL CENTERING

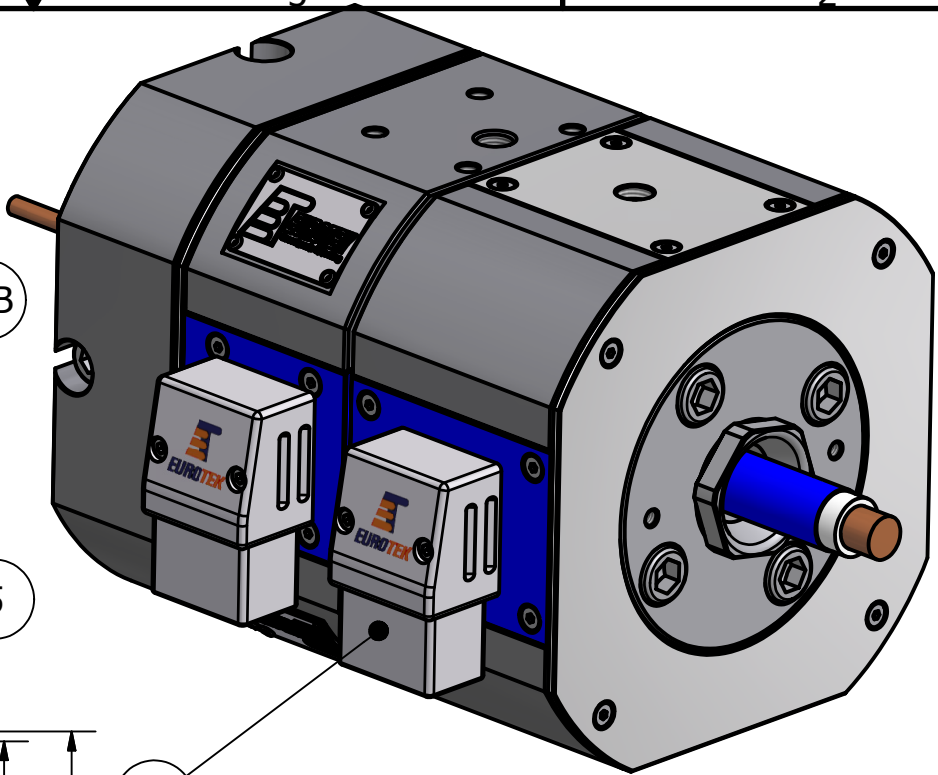
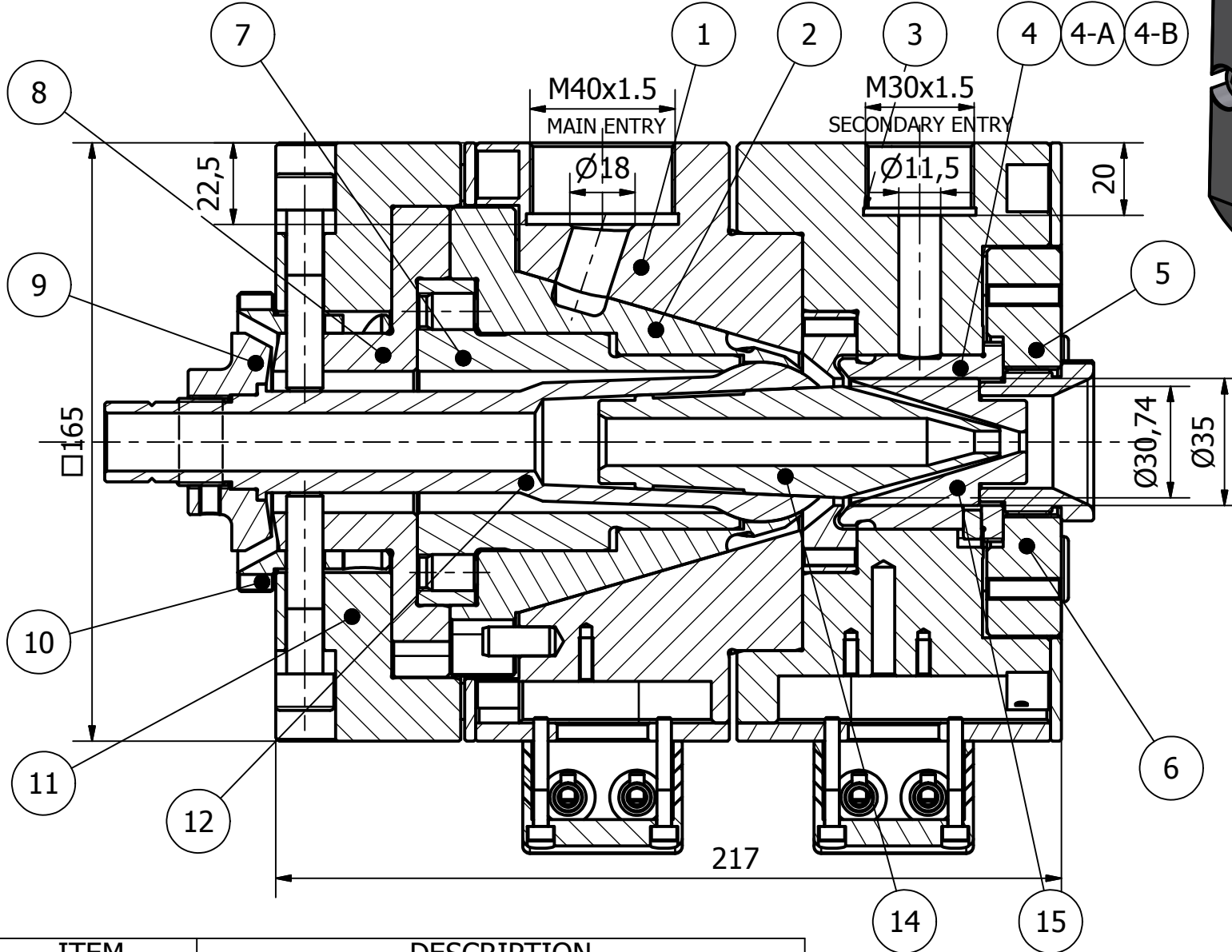

| APPLICATION | |
|-------------|--------------|
| | SINGLE LAYER |
| | STRIPE |
| | SKIN |

MAX CONDUCTOR: 12mm
 MAX OVER INSULATION: 16mm
 MAX TUBE DIE DIAMETER: 20mm

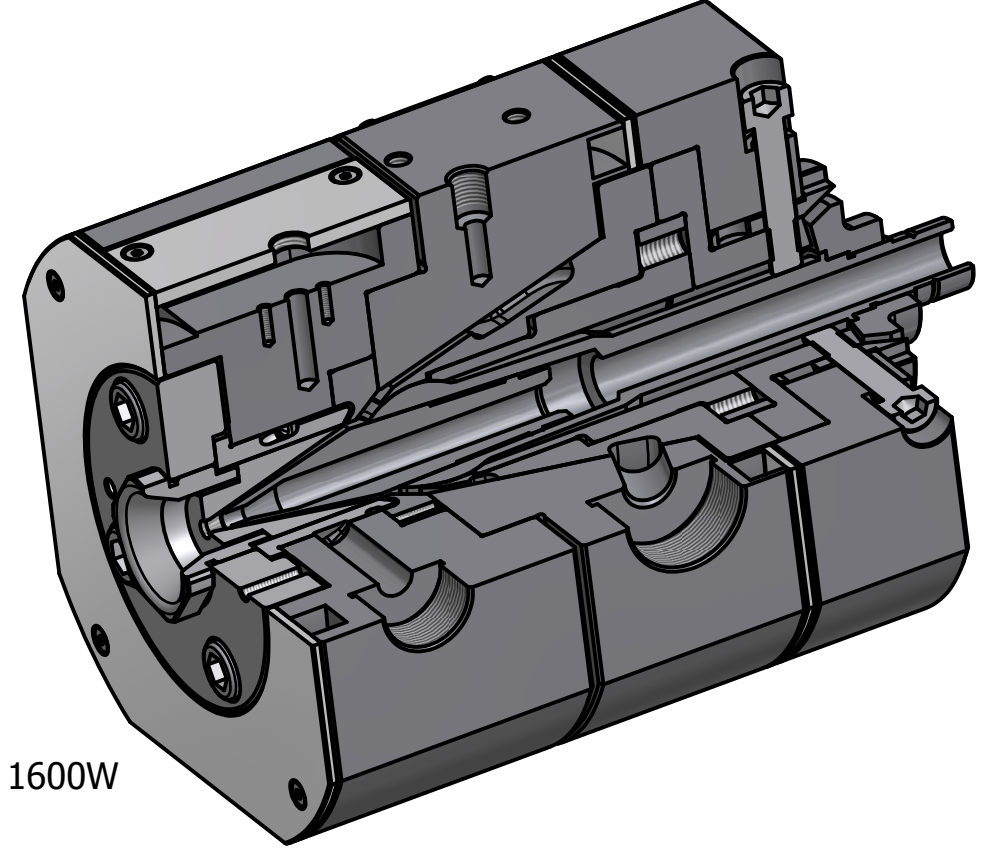

ELECTRICAL POWER HEAD BODY ZONE: 220V 1600W
 ELECTRICAL POWER DIE AREA: 220V 1600W

| ITEM | DESCRIPTION |
|------|--------------------------------------|
| 1 | MAIN BODY |
| 2 | PRESETTING CARTRIDGE |
| 3 | HOLDING RING PLATE |
| 4 | RING FOR SKIN |
| 4-A | RING FOR STRIPE |
| 4-B | NEUTRAL RING |
| 5 | HOLDING NUT FOR RING |
| 6 | ADJUSTING DIE NUT |
| 7 | NUT FOR SPHERICAL HOLDING WIRE-GUIDE |
| 8 | ADJUSTING SUPPORT |
| 9 | PRESETTING RING |
| 10 | PRESETTING NUT |
| 11 | REAR BODY |
| 12 | SPHERICAL HOLDING WIRE-GUIDE |
| 13 | POWER CONNECTION |
| 14 | TIP |
| 15 | DIE |

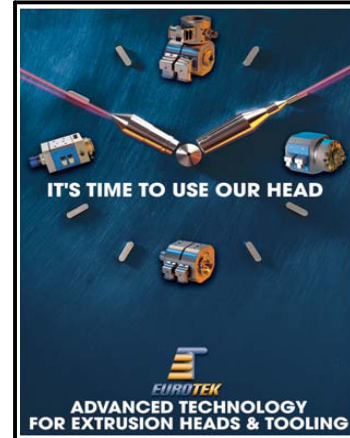

CROSSHEAD ECS-20/C

EUROTEK S.r.l.
 66034 LANCIANO (Ch)- Italy
 Phone:(+39) 0872 72581 FAX:(+39) 0872 711978
 www.eurotek-italy.it
 E-mail: info@eurotek-italy.it

